 REMO-HSE	HVC-150M-03	Datasheet
	High Voltage Cable	

Description: Shielded high voltage cable for 150 kV DC for use in electrostatic applications, e.g. liquid paint, powder coating and flocking systems.

Field of application: Electrostatic applications according to EN 50176 / EN 50177

Installation information: Accessory: multilam plug 4 mm; ground shielding at one end only

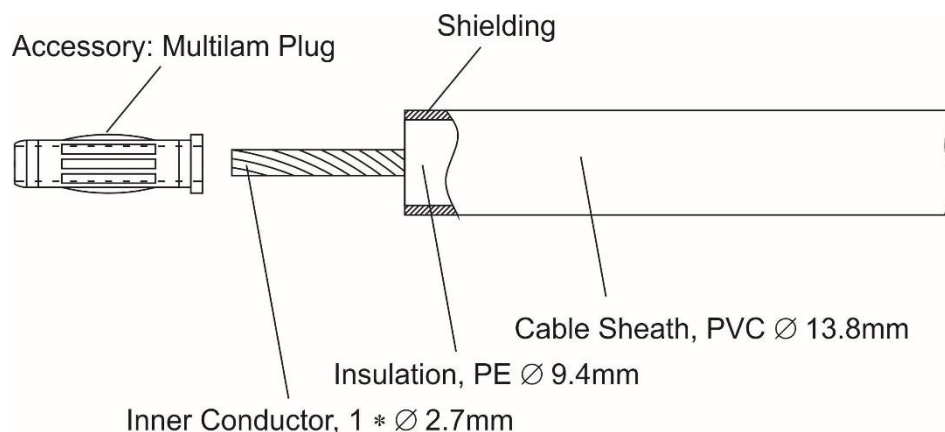

Mechanical Dimensions: ± 0.3 mm

Technical Specifications:

HV-Cable	
Rated Voltage:	150 kV DC
Test Voltage:	180 kV DC acc. to EN 50176/EN 50177
Inner Conductor:	1 × Ø 2.7 mm CU-bare
Insulation:	PE
Cable Sheath:	PVC black
Outer Diameter:	13.8 mm
Bending Radius:	> 30 times outer diameter
Operating Temperature:	-25 to +70°C

Date: 2011-10-17	REMO-HSE Hochspannungselektronik GmbH, Straubinger Str. 28, D - 94372 Rattiszell Tel.: +49 (0) 9964 / 6406 - 0 * Fax: +49 (0) 9964 / 6406 - 20 * Email: info@remo-hse.de	Page 1 / 1
---------------------	---	---------------